



1919  2023



DENTAL

Hartmetall-Bohrer

Carbide burs · Fraises au carbure · Fresas de carburo

Hartmetall-Fräser

Carbide cutters · Fraises au carbure · Fresas de carburo

Chirurgische-Bohrer

Surgical burs · Fraises chirurgicales · Fresas quirúrgicas

Wurzelkanal-Instrumente

Root canal instruments · Fraises & forets à canaux · Instrumentos para canales

Spezial-Werkzeuge

Special tools · Outils spéciaux · Herramientas especiales

Diamant-Instrumente

Diamond instruments · Instruments diamantés · Instrumentos de diamantados

ELA-Bohrerstände

ELA bur blocks · ELA porte-fraises · ELA portafresa

1**2****3****4****5****6****7**

Fig. -Nr.	ID- No.	Seite Page	Fig. -Nr.	ID- No.	Seite Page	Fig. -Nr.	ID- No.	Seite Page
C1	001 001	10	C139FX	289 140	20	836G	110 534	40
C1S	001 003	10	C139GX	289 190	22	836KR	157 524	40
C2	010 001	11	C141	001 291	28	836KRG	157 534	40
C3	040 001	11	141RF	001 291	28	837	111 524	40
C7	237 001	11	161RF	408 295	29	837G	111 534	40
C7L	238 001	11	C161	408 295	29	837KR	158 524	40
C21	107 006	12	162RF	408 297	29	837KR G	158 534	40
C21L	110 006	12	163RF	406 297	30	847	172 524	41
C21R	137 006	12	164RF	407 297	30	847G	172 534	41
C21RC	138 008	16	165RF	408 297	30	847KR	546 524	41
C21RX	137 019	16	166RF	409 297	31	847KR G	546 534	41
C23	168 006	12	167RF	410 297	31	855	197 524	41
C23FX	199 140	20	168RF	411 297	31	855 G	197 534	41
C23GX	199 190	21	180GR	679 336	34	855 F	197 514	41
C23L	171 006	12	191R	698 001	34	856	198 524	41
C23MF	196 140	23	C203	417 364	36	856G	198 534	41
C23MG	196 220	24	C207	150 001	15	856F	198 514	41
C23R	194 006	12	C219	467 211	36	856L	199 524	41
C23RL	197 006	13	C231	045 171	36	856L G	199 534	41
C23RX	194 019	16	C243K	297 072	16	856L F	199 514	41
C23SR	196 006	13	C244	289 072	16	858	165 524	41
C23SRX	196 019	13	C244K	298 072	16	858C	165 504	41
C23UR	194 006	13	C245	233 006	15	858F	165 514	41
C25R	238 006	13	C251FQ	274 134	25	858G	165 534	41
C30MF	225 140	23	C251FX	274 140	20	859	166 524	42
C30MG	225 220	24	C251GX	274 190	22	859C	166 504	42
C31	107 007	13	C251HX	274 220	23	859F	166 514	42
C31L	110 007	13	C251SX	274 224	23	859G	166 534	42
C31R	137 007	13	C257	146 006	15	859L	167 524	42
C33	168 007	14	303RF	603 391	36	859L G	167 534	42
C33L	170 007	14	368	257 524	43	859L F	167 514	42
C33R	194 007	14	368C	257 504	43	862	249 524	42
C33XL	171 007	14	368F	257 514	43	862C	249 504	42
C35R	238 007	15	379	277 524	43	862F	249 514	42
C41	001 071	15	379C	277 504	43	862G	249 534	42
C44E	499 072	15	379F	277 514	43	863	250 524	42
C47	237 071	15	379G	277 534	43	863C	250 504	42
C48	243 071	16	C416	201 175	19	863F	250 514	42
C71	001 175	19	C416GX	201 190	22	863G	250 534	42
C72	137 175	19	C460GX	116 190	22	878	289 524	42
C72FX	137 140	20	C486FX	137 140	21	878F	289 514	42
C72GX	137 190	21	C486GX	137 190	22	878G	289 534	42
C72SX	137 224	23	C487FX	292 140	21	878K	298 524	42
C73GX	277 190	21	C487GX	292 190	23	878KG	298 534	42
C75	260 175	19	C489FX	187 140	21	879	290 524	43
C75FX	260 140	20	801	001 524	39	879F	290 514	43
C75G	260 215	19	801L	697 524	39	879G	290 534	43
C75GX	260 190	21	801L G	697 534	39	879L	291 524	43
C77	237 175	19	801C	001 504	39	879L G	291 534	43
C77FX	237 140	20	801F	001 514	39	879L F	291 514	43
C77GX	237 190	22	801G	001 534	39	879K	299 524	43
C77MF	237 140	24	805	010 524	39	879K F	299 514	43
C77MG	237 220	24	805G	010 534	39	879K G	299 534	43
C78	257 175	19	807	225 524	39	880	140 524	43
C78MF	257 140	24	807G	225 534	39	880 F	140 514	43
C78MG	257 220	24	830	238 524	40	880 G	140 534	43
C79	194 175	19	830G	238 534	40	881	141 524	43
C79FQ	194 134	25	830L	239 524	40	881F	141 514	43
C79FX	194 140	20	830L G	239 534	40	881G	141 534	43
C79GX	194 190	22	835	107 524	40	882	142 524	43
C79HX	194 220	23	835G	107 534	40	882F	142 514	43
C138FQ	198 134	25	835KR	156 524	40	882G	142 534	43
C138FX	198 140	20	835KR G	156 534	40			
C138GX	198 190	22	836	110 524	40			

ID-No.	Fig.-Nr.	Seite Page	ID-No.	Fig.-Nr.	Seite Page	ID-No.	Fig.-Nr.	Seite Page
001 001	C1	10	168 006	C23	12	250 524	863	42
001 003	C1S	10	168 007	C33	14	250 534	863G	42
001 071	C41	15	170 007	C33L	14	257 140	C78MF	24
001 175	C71	19	171 006	C23L	12	257 175	C78	19
001 291	C141	28	171 007	C33XL	14	257 220	C78MG	24
001 291	141RF	28	172 524	847	41	257 504	368C	43
001 504	801C	39	172 534	847G	41	257 514	368F	43
001 514	801F	39	187 140	C489FX	21	257 524	368	43
001 524	801	39	194 006	C23R	12	260 140	C75FX	20
001 534	801G	39	194 006	C23UR	13	260 175	C75	19
010 001	C2	11	194 007	C33R	14	260 190	C75GX	21
010 524	805	39	194 019	C23RX	16	260 215	C75G	19
010 534	805G	39	194 134	C79FQ	25	274 134	C251FQ	25
040 001	C3	11	194 140	C79FX	20	274 140	C251FX	20
045 171	C231	36	194 175	C79	19	274 190	C251GX	22
107 006	C21	12	194 190	C79GX	22	274 220	C251HX	23
107 007	C31	13	194 220	C79HX	23	274 224	C251SX	23
107 524	835	40	196 006	C23SR	13	277 190	C73GX	21
107 534	835G	40	196 019	C23SRX	13	277 504	379C	43
110 006	C21L	40	196 140	C23MF	23	277 514	379F	43
110 007	C31L	13	196 220	C23MG	24	277 524	379	43
110 524	836	40	197 006	C23RL	13	277 534	379G	43
110 534	836G	40	197 524	855	41	289 072	C244	16
111 524	837	40	197 534	855G	41	289 140	C139FX	20
111 534	837G	40	197 514	855F	41	289 190	C139GX	22
116 190	C460GX	22	198 134	C138FQ	25	289 514	878F	42
137 006	C21R	12	198 140	C138FX	20	289 524	878	42
137 007	C31R	13	198 190	C138GX	22	289 534	878G	42
137 019	C21RX	16	198 524	856	41	290 514	879F	43
137 140	C72FX	20	198 534	856G	41	290 524	879	43
137 140	C486FX	21	198 514	856F	41	290 534	879G	43
137 175	C72	19	199 524	856L	41	291 524	879L	43
137 190	C72GX	21	199 534	856LG	41	291 534	879LG	43
137 190	C486GX	22	199 514	856LF	41	291 514	879LF	43
137 224	C72SX	23	199 140	C23FX	20	292 140	C487FX	21
138 008	C21RC	16	199 190	C23GX	21	292 190	C487GX	23
140 524	880	43	201 175	C416	19	297 072	C243K	16
140 514	880F	43	201 190	C416GX	22	298 072	C244K	16
140 534	880G	43	225 140	C30MF	23	298 524	878K	42
141 524	881	43	225 220	C30MG	24	298 534	878K G	42
141 514	881F	43	225 524	807	39	299 514	879K F	43
141 534	881G	43	225 534	807G	39	299 524	879K	43
142 524	882	43	233 006	C245	15	299 534	879K G	43
142 514	882F	43	237 001	C7	11	406 297	163RF	30
142 534	882G	43	237 071	C47	15	407 297	164RF	30
146 006	C257	15	237 140	C77FX	20	408 295	161RF	29
150 001	C207	15	237 140	C77MF	24	408 295	C161	29
156 524	835KR	40	237 175	C77	19	408 297	162RF	29
156 534	835KR G	40	237 190	C77GX	22	408 297	165RF	30
157 524	836KR	40	237 220	C77MG	24	409 297	166RF	31
157 534	836KR G	40	238 001	C7L	11	410 297	167RF	31
158 524	837KR	40	238 006	C25R	13	411 297	168RF	31
158 534	837KR G	40	238 007	C35R	15	417 364	C203	36
165 504	858C	41	238 524	830	40	467 211	C219	36
165 514	858F	41	238 534	830G	40	499 072	C44E	15
165 524	858	41	239 524	830L	40	546 524	847KR	41
165 534	858G	41	239 534	830L G	40	546 534	847KR G	41
166 504	859C	42	243 071	C48	16	603 391	303RF	36
166 514	859F	42	249 504	862C	42	679 336	180GR	34
166 524	859	42	249 514	862F	42	697 524	801L	39
166 534	859G	42	249 524	862	42	697 534	801LG	39
167 524	859L	42	249 534	862G	42	698 001	191R	34
167 534	859LG	42	250 504	863C	42			
167 514	859LF	42	250 514	863F	42			



Der ELA-Katalog beinhaltet rotierende Instrumente vorwiegend für den Dentalbereich, die Industrie, die Schmuckwarenindustrie, die Automobilbranche und den Hobbymarkt. Die folgende Aufstellung gibt eine Übersicht von Anwendungsempfehlungen für Medizinprodukte im Praxisbereich.



The ELA catalogue covers rotary instruments mainly for the dental field, the industry, the jewellery industry, the automobile branch as well as the hobby market. The following listing provides you with an outline of recommended applications for medical products in the line of medical practices.

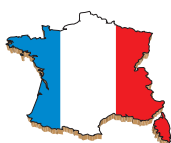

Le catalogue ELA comprend les instruments rotatifs surtout pour le domaine dental, l'industrie de la bijouterie, le secteur automobile et du bricolage. Le relevé suivant vous donne une vue d'ensemble des applications recommandées pour les produits médicaux dans le domaine des cabinets médicaux.



El catálogo ELA comprende instrumentos rotativos principalmente para el sector dental, la industria, la industria de joyería, el ramo automovil así como el mercado de bricolaje. El listado siguiente da un cuadro de conjunto de las aplicaciones recomendadas para productos medicinales en el campo de los consultorios médicos.

Kavitätenpräparation

Cavity preparation
Préparation cavitaire
Preparación de las cavidades



*Schaftarten/Types of shanks/
Types de tiges/Tipos de vastagos:*
Winkelstück/Right angle/Contre angle/
Contrángulo
FG/FG/FG/FG
C1, C1S, C2, C7, C7L, C21, C21L, C21R, C23,
C23L, C23R, C23UR, C23RL, C25R, C31, C31L,
C31R, C33, C33L, C33XL, C33R, C35R, C207,
C245, C257

Aufbohren alter Füllungen

Drilling of old fillings
Retrait des vieilles obturations
Extracción de obturaciones existentes



*Schaftarten/Types of shanks/
Types de tiges/Tipos de vastagos:*
Winkelstück/Right angle/Contre angle/
Contrángulo
FG/FG/FG/FG
C1, C7, C7L, C21RX, C21RC, C23RX, C25R

Kronentrennen

Crown cutting
Séparation des couronnes
Separación de las coronas



*Schaftarten/Types of shanks/
Types de tiges/Tipos de vastagos:*
FG/FG/FG/FG
C21RX, C21RC, C23RX

Kronenstumpfpräparation

Crown preparation
Préparation coronaire
Preparación coronaria



*Schaftarten/Types of shanks/
Types de tiges/Tipos de vastagos:*
Winkelstück/Right angle/Contre angle/
Contrángulo
FG/FG/FG/FG
C1, C21, C21L, C21R, C23, C23L, C23R,
C23RL, C31, C31L, C31R, C33, C33L, C33R,
C245, C257

Füllungsbearbeitung

Filling process
Préparation des obturations
Preparación de las obturaciones



*Schaftarten/Types of shanks/
Types de tiges/Tipos de vastagos:*
Winkelstück/Right angle/Contre angle/
Contrángulo
FG/FG/FG/FG
C41, C47, C48

Kieferchirurgie

Maxillo-Facial surgery
Chirurgie maxillo-faciale
Cirugía maxilofacial



*Schaftarten/Types of shanks/
Types de tiges/Tipos de vastagos:*
Handstück/Handpiece/Pièce à main/
Pieza de mano/Winkelstück/Right angle/
Contre angle/Contrángulo
FG/FG/FG/FG
C1, C21, C31, C33, C33R, C161

Kieferorthopädie

Orthodontics
Orthodontie
Ortodoncia



*Schaftarten/Types of shanks/
Types de tiges/Tipos de vastagos:*
Winkelstück/Right angle/Contre angle/
Contrángulo
C23R



Nummernsystem

Die ID-No. gibt Auskunft über den Werkstoff des Arbeitsteils **A**, die Schaftart **B**, die Gesamtlänge **C**, Form und Ausführung des Arbeitsteils **D** sowie über den größten Kopfdurchmesser **E** des Instrumentes.



Numbering System

The ID-No. describes the type of material used in the head of the rotary instrument **A**, type of shank **B**, overall length **C**, shape and type of working part **D** as well as the largest head diameter **E** of the instrument.



Le système de numérotation

Le ID-No. est également le numéro de commande et indique le matériau de la partie travaillante **A**, le type de tige **B**, la longueur totale **C**, la forme et l'exécution de la partie travaillante **D**, ainsi que le plus grand diamètre de tête **E** de l'instrument.



Sistema de numeración

El ID-No. indica el tipo del material de la parte activa **A**, el tipo de mango **B**, la longitud total **C**, forma y tipo de la parte activa **D**, así como el mayor diámetro de la cabeza **E** del instrumento.

A

Werkstoff des Arbeitsteils
Material of working part
Matériau de la tête
Material de la parte activa

Hartmetall
Tungsten carbide
Carbure de tungstène
Carburo de tungsteno

500 204 107 006 012

B C

Schaft und Gesamtlänge
Shank and overall length
Tige et longueur totale
Mango y longitud total

Winkelstück
Right - angle
Contre - angle
Contra - ángulo

500 204 107 006 012

D

Form und Ausführung
Shape and type of finish on working part
Forme et type
Forma y tipo

Zylinder, Bohrerverzahnung,
rechtsgewunden
Cylinder, bur tothing,
right-hand twist
Cylindre, denture,
helicoidale à droite
Cilíndro, dentado,
helicoidal a la derecha

500 204 107 006 012

E

Nenngröße, größter Ø des
Arbeitsteils in 1/10 mm
Nominal size, largest head
diameter in 1/10 mm
Taille nominale, le plus
grand diamètre de tête en 1/10 mm
Tamaño nominal, el mayor
diámetro de la parte activa en 1/10 mm

Größe
Size
Taille
Tamaño



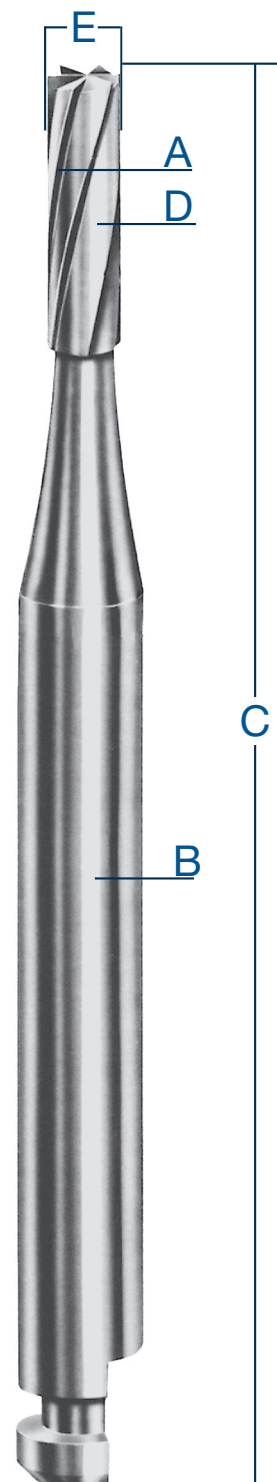







500 204 107 006 012
1,2 mm



Beispiel:, Example:, Exemple:, Ejemplo:

ID-No. 500 204 107 006 012

Types of shanks and total lengths
Types de tiges et longueurs totales
Tipos de vástagos y longitudes totales

ID-No.	Bezeichnung	Länge mm	∅ mm
 ... 104	Handstück, normal Handpiece, normal length Pièce à main, longueur normale Pieza de mano, largo regular	44,00	2,35
 ... 105	Handstück, chirurgische Länge Handpiece, surgical length Pièce à main, longueur chirurgicale Pieza de mano, largo quirúrgicas	65,00	2,35
 ... 202	Winkelstück, Miniatur Right angle, miniature Contre angle, miniature Contrángulo, miniatura	16,50	2,35
 ... 204	Winkelstück, normal Right angle, normal length Contre angle, normale Contrángulo, largo regular	22,50	2,35
 ... 205	Winkelstück, extra lang Right angle, extra long Contre angle, extra-long Contrángulo, extra largo	26,50	2,35
 ... 206	Winkelstück, chirurgische Länge Right angle, surgical length Contre angle, longueur chirurgicale Contrángulo, largo quirúrgicas	34,00	2,35
 ... 313	FG, shorty FG, Shorty FG, Shorty FG, Shorty	16,50	1,60
 ... 314	FG, normal FG, normal length FG, longueur normale FG, largo regular	19,00	1,60
 ... 315	FG, extra lang FG, extra long FG, extra-long FG, extra largo	21,00	1,60
 ... 316	FG, surgical FG, Surgical FG, Surgical FG, Surgical	25,40	1,60

ID-No.	ø mm	alte Nummer
... 004	0,40	-
... 005	0,50	4/0
... 006	0,60	3/0
... 007	0,70	2/0
... 008	0,80	0
... 009	0,90	1
... 010	1,00	2
... 011	1,10	-
... 012	1,20	3
... 013	1,30	-
... 014	1,40	4
... 015	1,50	-
... 016	1,60	5
... 017	1,70	-
... 018	1,80	6
... 019	1,90	-
... 020	2,00	-
... 021	2,10	7
... 022	2,20	-
... 023	2,30	8
... 024	2,40	-
... 025	2,50	9
... 026	2,60	-
... 027	2,70	10
... 028	2,80	-
... 029	2,90	11
... 030	3,00	-
... 031	3,10	12
... 033	3,30	13

ID-No.	ø mm	alte Nummer
... 035	3,50	14
... 037	3,70	15
... 040	4,00	16
... 042	4,20	17
... 045	4,50	18
... 047	4,70	19
... 050	5,00	20
... 055	5,50	21
... 060	6,00	22
... 070	7,00	24
... 080	8,00	26
... 100	10,0	30
... 120	12,0	34
... 140	14,0	38
... 160	16,0	42

Aufbereitungshinweise und allgemeine Sicherheitshinweise

Unsere Aufbereitungshinweise und die allgemeinen Sicherheitshinweise finden Sie als PDF Download unter www.emil-lange.de - Rubrik Anwendungshinweise. Bei Bedarf senden wir Ihnen diese Hinweise auch gerne zu.

Instructions for reconditioning and general notes on safety

You will find our instructions for reconditioning and the general notes on safety as PDF download under www.emil-lange.de – in the Instruction of use section. We shall also be pleased to send you these instructions on request.

Indications de préparation et indications de sécurité générales

Vous les trouverez en fichier PDF dans la rubrique „recommandations“ sur notre site internet <http://www.emil-lange.de>. A votre demande écrite, nous nous ferons le plaisir de vous les transmettre par courriel ou voie postale.

Indicaciones de preparación e indicaciones de seguridad generales

Pueden encontrar como PDF Download bajo www.emil-lange.de nuestras indicaciones de preparación y las indicaciones de seguridad. En caso necesario estamos gustoso dispuestos a hacerles llegar estas indicaciones.

Hartmetall-Bohrer

Carbide burs · Fraises au carbure · Fresas de carburo



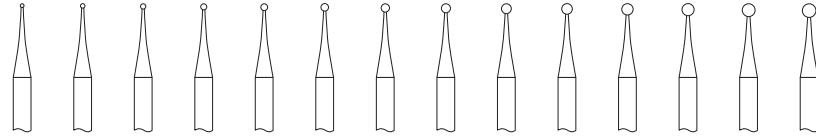

C1

ID-No.	004	005	006	007	008	009	010	011	012	013	014	015	016	017
500 104 001 001 ...	004	005	006	007	008	009	010	011	012	013	014	015	016	017
500 105 001 001 ...							010		012		014		016	
500 202** 001 001 ...					008	009	010		012		014		016	
500 204 001 001 ...	004	005	006	007	008	009	010		012		014		016	
500 205 001 001 ...	004	005	006	007	008	009	010		012		014		016	
500 206 001 001 ...	004	005	006	007	008	009	010		012		014		016	
500 313** 001 001 ...		005	006	007	008	009	010		012		014		016	
500 314 001 001 ...	004	005	006	007	008	009	010		012		014		016	
500 315 001 001 ...	004	005	006	007	008	009	010		012		014		016	
500 316* 001 001 ...					008*	009*	010*		012*		014*		016*	
US-No.	1/4	1/2	-	1	-	2	-	3	-	4	-	5	-	

316 *max. 160.000 min⁻¹

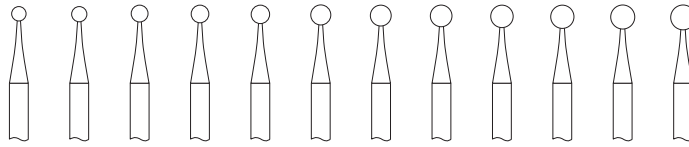

C1

ID-No.	018	019	021	022	023	025	026	027	028	029	030	031
500 104 001 001 ...	018	019	021	022	023	025	026	027	028	029	030	031
500 105 001 001 ...	018		021		023	025		027		029		031
500 202** 001 001 ...	018		021		023							
500 204 001 001 ...	018		021		023	025		027		029		031
500 205 001 001 ...	018		021		023	025		027		029		031
500 206 001 001 ...	018		021		023	025		027		029		031
500 313** 001 001 ...	018		021		023							
500 314 001 001 ...	018		021		023							
500 315 001 001 ...	018		021		023							
500 316* 001 001 ...	018*		021*		023*							
US-No.	6	-	7	-	8	9	10	-	-	-	11	

316 *max. 160.000 min⁻¹

... **202****
... **313****

WSt-Mini und FG-Shorty auch geeignet für Kinderzahnheilkunde und Arbeiten bei eingeschränkter Mundöffnung

RA-Mini and FG-Shorty also suitable for pediatric dentistry and work at restricted mouth opening

CA-Mini et FG-Shorty pour chirurgie dentaire d'enfants et travaux à orifice buccal restreint

CA-Mini y FG-Shorty para odontología pediátrica así como trabajos a orificio bucal restringido

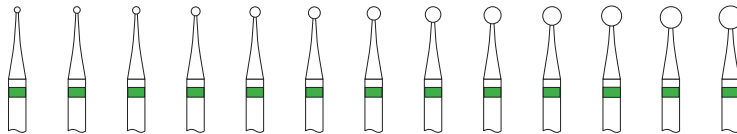

C1 S

ID-No.	008	009	010	012	014	016	018	021	023	025	027	029	031
500 104 001 003 ...	008	009	010	012	014	016	018	021	023	025	027	029	031
500 204 001 003 ...	008	009	010	012	014	016	018	021	023	025	027	029	031
500 205 001 003 ...	008	009	010	012	014	016	018	021	023	025	027		
500 314 001 003 ...	008	009	010	012	014	016	018	021	023				
500 316* 001 003 ...	008*	009*	010*	012*	014*	016*	018*	021*	023*				

316 *max. 160.000 min⁻¹

**Zum Exkavieren -
Schnittfreudige Verzahnung**

*For excavating -
High cutting efficiency
Pour tailler une cavité -
Denture de taille effective
Para excavar -
Alta efectividad de corte*

H · HP · PM · PM

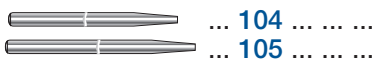

... **104**
... **105**

W · RA · CA · CA



... **202**
... **204**
... **205**
... **206**

FG · FG · FG · FG

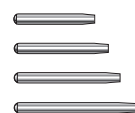

... **313**
... **314**
... **315**
... **316**

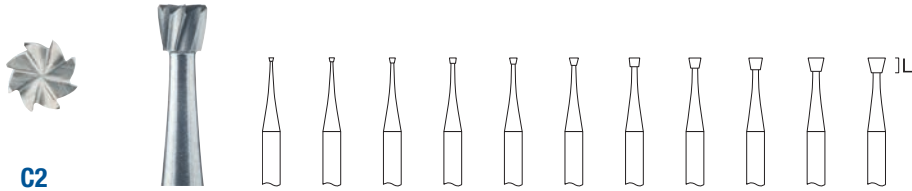

C2

	ID-No.	006	007	008	009	010	012	014	016	018	021	023
500 104	010 001 ...	006	007	008	009	010	012	014	016	018	021	023
500 204	010 001 ...	006	007	008	009	010	012	014	016	018	021	023
500 314	010 001 ...	006	007	008	009	010	012	014	016	018	021	023
US-No.		33 ^{1/2}	-	34	-	35	36	37	38	39	40	41
L mm		0,5	0,6	0,7	0,8	0,9	1,0	1,2	1,4	1,5	1,7	1,9

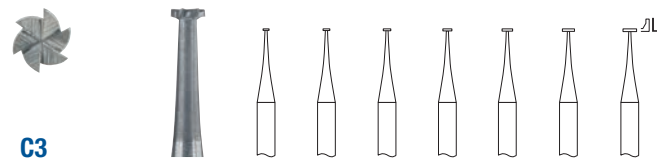

C3

	ID-No.	008	009	010	012	014	016	018
500 104	040 001 ...	008	009	010	012	014	016	018
US-No.		-	14	-	-	-	16	-
L mm		0,20	0,22	0,25	0,27	0,30	0,33	0,36

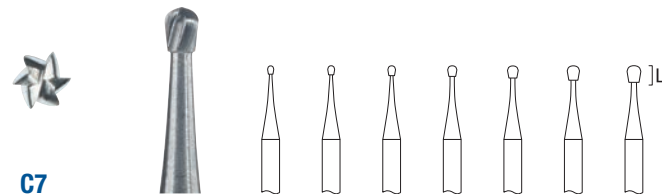

C7

	ID-No.	008	009	010	012	014	016	018
500 104	237 001 ...	008	009	010	012	014	016	018
500 204	237 001 ...	008	009	010	012	014	016	018
500 314	237 001 ...	008	009	010	012	014	016	018
US-No.		44	-	45	46	47	-	49
L mm		1,1	1,2	1,3	1,4	1,6	1,9	2,2

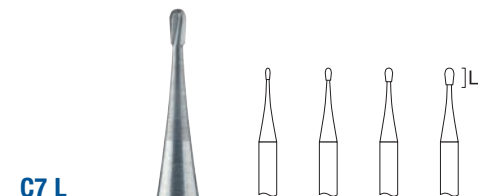

C7 L

	ID-No.	006	008	010	012
500 104	238 001 ...	006	008	010	012
500 204	238 001 ...	006	008	010	012
500 314	238 001 ...	006	008	010	012
US-No.		329	330	331	332
L mm		1,5	1,6	1,8	2,2

H · HP · PM · PM



... 104 ...

W · RA · CA · CA



... 204 ...

FG · FG · FG · FG



... 314 ...



Hartmetall-Bohrer

Carbide burs . Fraises au carbure . Fresas de carburo

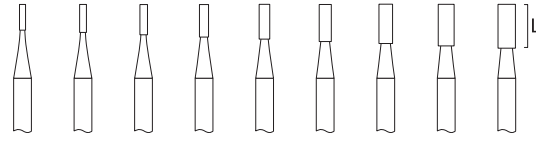

C21

	ID-No.	008	009	010	012	014	016	018	021	023
500 104	107 006 ...	008	009	010	012	014	016	018	021	023
500 204	107 006 ...	008	009	010	012	014	016	018	021	023
500 314	107 006 ...	008	009	010	012	014	016	018	021	023
500 316	107 006 ...	008*	009*	010*	012*	014*	016*	018*	021*	023*
	US-No.	56	-	57	58	59	60	61	62	63
	L mm	3,4	3,7	4,0	4,3	4,6	4,9	5,2	5,5	5,8
		316 *max. 160.000 min ⁻¹								

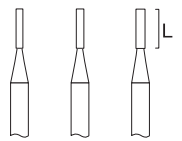

C21 L

	ID-No.	009	010	012
500 104	110 006 ...	009	010	012
500 204	110 006 ...	009	010	012
500 314	110 006 ...	009*	010*	012*
	US-No.	-	57L	58L
	L mm	5,2	5,2	5,2
		314 *max. 160.000 min ⁻¹		

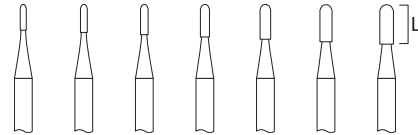

C21 R

	ID-No.	008	009	010	012	014	016	018
500 104	137 006 ...	008	009	010	012	014	016	018
500 204	137 006 ...	008	009	010	012	014	016	018
500 314	137 006 ...	008	009	010	012	014	016	018
	US-No.	1156	-	1157	1158	1159	-	-
	L mm	3,4	3,7	4,0	4,3	4,6	4,9	5,2

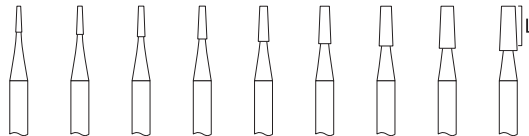

C23

	ID-No.	008	009	010	012	014	016	018	021	023
500 104	168 006 ...	008	009	010	012	014	016	018	021	023
500 204	168 006 ...	008	009	010	012	014	016	018		
500 314	168 006 ...	008	009	010	012	014	016	018		
	US-No.	169	-	170	171	-	172	-		
	L mm	3,4	3,7	4,0	4,3	4,6	4,9	5,2	5,5	5,8

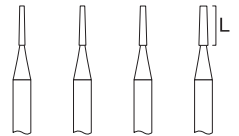

C23 L

	ID-No.	008	009	010	012
500 104	171 006 ...	008	009	010	012
500 204	171 006 ...	008	009	010	012
500 314	171 006 ...	008*	009*	010*	012*
	US-No.	169L	-	170L	171L
	L mm	5,2	5,2	5,2	5,22
		314 *max. 160.000 min ⁻¹			

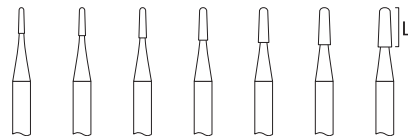

C23 R

	ID-No.	008	009	010	012	014	016	018
500 104	194 006 ...	008	009	010	012	014	016	018
500 204	194 006 ...	008	009	010	012	014	016	018
500 314	194 006 ...	008	009	010	012	014	016	018
	US-No.	-	-	1170	1171	-	1172	-
	L mm	3,4	3,7	4,0	4,3	4,6	4,9	5,2

- Zum Entfernen von Klebstoff
- for removal of adhesive
- pour enlever les adhésifs
- para quitar el adhesivo

H · HP · PM · PM

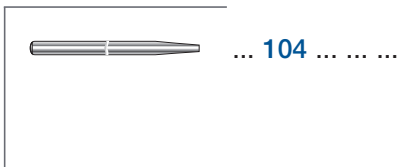

W · RA · CA · CA

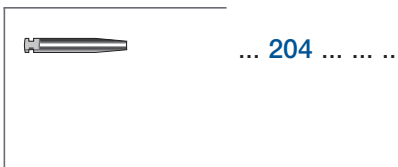

FG · FG · FG · FG

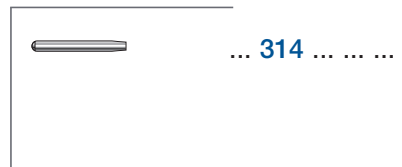

C23 UR

ID-No.	016	018
500 204 194 006 ...	016	018
500 314 194 006 ...		018
L mm	5,2	5,2

C23 SRX

ID-No.	010
500 104 196 019 ...	010
L mm	4,2

C23 SR

ID-No.	008	009	010
500 104 196 006 ...	008	009	010
L mm	4,2	4,2	4,2

C23 RL

ID-No.	010
500 104 197 006 ...	010
500 204 197 006 ...	010
500 314 197 006 ...	010*
L mm	5,2
314 *max. 160.000 min ⁻¹	

C25 R

ID-No.	008	009	010	012	014	016	018	021	023
500 204 238 006 ...	008	009	010	012	014	016	018	021	023
500 314 238 006 ...	008	009	010	012	014	016	018	021	023
US-No.	330L	-	331L	332L					
L mm	2,5	2,8	3,7	3,7	4,1	4,1	4,5	4,6	4,9

C31

ID-No.	008	009	010	012	014	016	018	021	023
500 104 107 007 ...	008	009	010	012	014	016	018	021	023
500 105 107 007 ...			010	012	014	016			
500 204 107 007 ...	008	009	010	012	014	016	018	021	023
500 205 107 007 ...	008	009	010	012	014	016	018	021	023
500 314 107 007 ...	008	009	010	012	014	016			
500 316 107 007 ...	008*	009*	010*	012*	014*	016*	018*	021*	
US-No.	556	-	557	558	559	560	561	562	563
L mm	3,4	3,7	4,0	4,3	4,6	4,9	5,2	5,5	5,8
316 *max. 160.000 min ⁻¹									

C31 L

ID-No.	009	010	012
500 104 110 007 ...	009	010	012
500 204 110 007 ...	009	010	012
500 314 110 007 ...	009*	010*	012*
500 316 110 007 ...	009*	010*	012*
US-No.	-	557L	558L
L mm	5,2	5,2	5,2
314/316 *max. 160.000 min ⁻¹			

C31 R

ID-No.	008	009	010	012	014	016	018	021	023
500 104 137 007 ...	008	009	010	012	014	016	018	021	023
500 204 137 007 ...	008	009	010	012	014	016	018		
500 314 137 007 ...	008	009	010	012	014	016	018		
500 316 137 007 ...			010*	012*	014*	016*	018*		
US-No.	1556	-	1557	1558	1559	1560	1561	-	-
L mm	3,4	3,7	4,0	4,3	4,6	4,9	5,2	5,5	5,8
316 *max. 160.000 min ⁻¹									

H · HP · PM · PM

	... 104 ...
	... 105 ...

W · RA · CA · CA

	... 204 ...
	... 205 ...

FG · FG · FG · FG

	... 314 ...
	... 316 ...



Hartmetall-Bohrer

Carbide burs · Fraises au carbure · Fresas de carburo

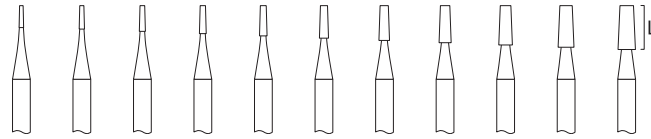

C33

ID-No.	006	007	008	009	010	012	014	016	018	021	023
500 104 168 007 ...	006	007	008	009	010	012	014	016	018	021	023
500 105 168 007 ...						012	014	016	018	021	023
500 204 168 007 ...			008	009	010	012	014	016	018	021	023
500 205 168 007 ...			008	009	010	012	014	016	018	021	023
500 314 168 007 ...		008	009	010	012	014	016	018	021	023	
500 316 168 007 ...		008*	009*	010*	012*	014*	016*	018*	021*		
316 *max. 160.000 min ⁻¹											
US-No.	699	-	700	701	-	702	-	703	704		
L mm	2,9	3,1	3,4	3,7	4,0	4,3	4,6	4,9	5,2	5,5	5,8

C33 L

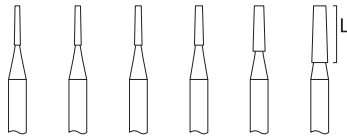

ID-No.	008	009	010	012	016	021
500 104 170 007 ...	008	009	010	012	016	021
500 204 170 007 ...	008	009	010	012		
500 314 170 007 ...	008*	009*	010*	012*		
500 316 170 007 ...	008*	009*	010*	012*		
314/316 *max. 160.000 min ⁻¹						
US-No.	699L	-	700L	701L	702L	703L
L mm	5,2	5,2	5,2	5,2	6,0	7,5

C33 XL

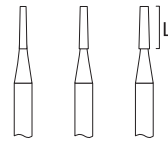

ID-No.	010	012	014
500 104 171 007 ...	010	012	014
500 314 171 007 ...	010*	012*	014*
314 *max. 160.000 min ⁻¹			
L mm	5,6	5,6	5,6

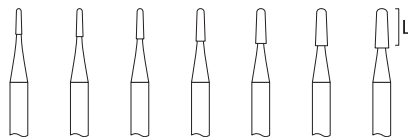

C33 R

ID-No.	008	009	010	012	014	016	018
500 104 194 007 ...	008	009	010	012	014	016	
500 204 194 007 ...	008	009	010	012	014	016	
500 205 194 007 ...	008	009	010	012	014	016	
500 314 194 007 ...	008	009	010	012	014	016	018
500 316 194 007 ...	008*	009*	010*	012*	014*	016*	
316 *max. 160.000 min ⁻¹							
L mm	3,4	3,7	4,0	4,3	4,6	4,9	5,2

H · HP · PM · PM



W · RA · CA · CA



FG · FG · FG · FG

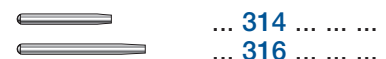

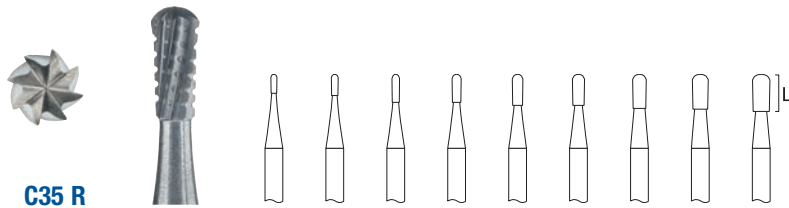

C35 R		ID-No.	008	009	010	012	014	016	018	021	023
500	104	238 007 ...	008	009	010	012	014	016	018	021	023
500	204	238 007 ...	008	009	010	012	014	016	018	021	023
500	314	238 007 ...	008	009	010	012	014	016	018	021	023
		L mm	2,5	2,8	3,7	3,7	4,1	4,1	4,5	4,6	4,9

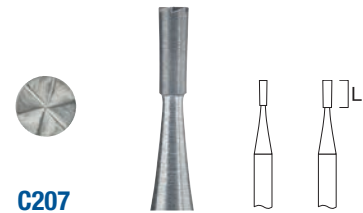

C207		ID-No.	010	012
500	104	150 001 ...	010	012
500	204	150 001 ...	010	012
500	314*	150 001 ...	010*	012*
		314	*max. 160.000 min ⁻¹	
		US-No.	957	958
		L mm	3,3	3,6

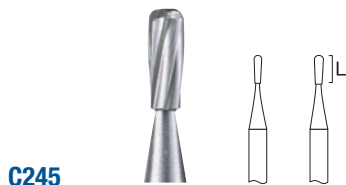

C245		ID-No.	010	012
500	204	233 006 ...	010	012
500	314	233 006 ...	010	012
		US-No.	245	246
		L mm	3,7	3,8

Sockwellbohrer
 sockwell burs
 fraises sockwell
 fresas sockwell



C257		ID-No.	010	012
500	204	146 006 ...	010	012
500	314	146 006 ...	010	012
		US-No.	257	258
		L mm	4,0	4,3

Hartmetall-Finierer

Carbide finishers · Fraises à finir au carbure de tungstène · Fresas para acabar

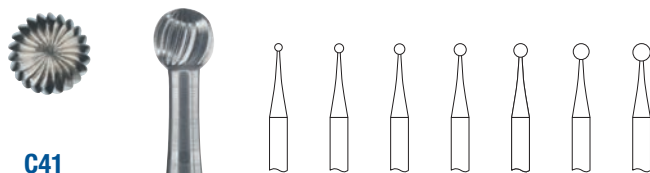

C41		ID-No.	010	012	014	016	018	021	023
500	104	001 071 ...	010	012	014	016	018	021	023
500	204	001 071 ...	010	012	014	016	018	021	023
500	314	001 071 ...	010	012	014	016	018	021	023



C44 E		ID-No.	014	023
500	314	499 072 ...	014	023
		L mm	3,3	3,8



C47		ID-No.	014	016	018	021	023
500	204	237 071 ...	014	016	018	021	023
500	314	237 071 ...	014	016	018	021	023
		L mm	1,6	1,9	2,2	2,4	2,6

H · HP · PM · PM

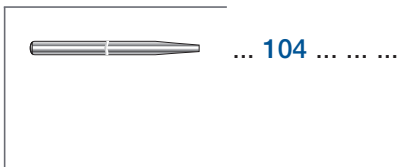

W · RA · CA · CA

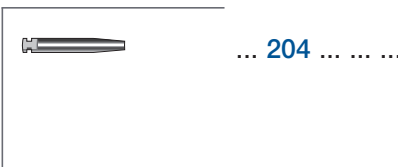

FG · FG · FG · FG

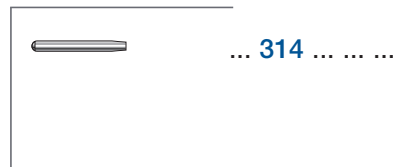



Hartmetall-Bohrer

Carbide burs · Fraises au carbure · Fresas de carburo

Hartmetall-Finierer

Carbide finishers · Fraises à finir au carbure de tungstène · Fresas para acabar

1

C48

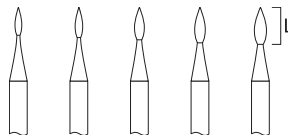
ID-No.	009	010	012	014	016
500 104 243 071 ...	009	010	012	014	016
500 204 243 071 ...	009	010	012	014	016
500 314 243 071 ...	009	010	012	014	016
L mm	3,7	4,0	4,3	4,7	4,9

C243 K



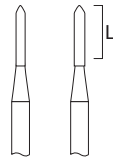

ID-No.	014	016
500 204 297 072 ...		016
500 314 297 072 ...	014	
L mm	6,0	6,0

C244

ID-No.	012	014
500 204 289 072 ...	012	
500 314 289 072 ...	012*	014*
314 *max. 120.000 min ⁻¹		
L mm	8,0	8,0

C244 K

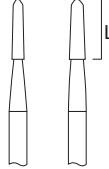



ID-No.	016	021
500 204 298 072 ...		021
500 314 298 072 ...	016*	021*
314 *max. 120.000 min ⁻¹		
L mm	8,0	8,0

Kronentrenner

crown cutters · maxi cut métal · tagliacorone

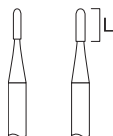
C21 RX

ID-No.	010	012
500 314 137 019 ...	010*	012*
L mm	4,0	4,3
314 *max. 160.000 min ⁻¹		

C23 RX

ID-No.	010	012
500 314 194 019 ...	010*	012*
L mm	4,0	4,3
314 *max. 160.000 min ⁻¹		

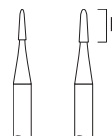
C21 RC

ID-No.	012
500 314 138 008 ...	012*
L mm	3,0
314 *max. 160.000 min ⁻¹	

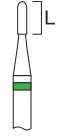
H · HP · PM · PM

 ... **104** ...

W · RA · CA · CA

 ... **204** ...

FG · FG · FG · FG



















 ... **314** ...

Hartmetall-Fräser

Laboratory carbide cutters · Fraises carbure pour laboratoire

Fresas de carburo para laboratorios



	<i>Farbcodierung</i> Colour code Code couleurs Código colores	<i>Verzahnung</i> Toothing Denture Dentado	<i>Fig.</i> Fig. Fig. Fig.	<i>ID - No.</i> ID - No. ID - No. ID - No.	
	<i>blauer Ring</i> blue ring anneau bleu anillo azul	<i>Standardverzahnt</i> Plain cut, medium Denture simple Dentado simple, medio		175	
	<i>grüner Ring</i> green ring anneau vert anillo verde	<i>Grobverzahnt</i> Plain cut, coarse Denture simple, grosse Dentado simple, grueso	... G	215	
	<i>gelber Ring</i> yellow ring anneau jaune anillo amarillo	<i>Kreuzverzahnt extra fein</i> x-cut, extra fine Denture croisée, extra fine Dentado cruzado, extra fino	... EX	141	
	<i>roter Ring</i> red ring anneau rouge anillo rojo	<i>Kreuzverzahnt fein</i> x-cut, fine Denture croisée, fine Dentado cruzado, fino	... FX	140	
	<i>blauer Ring</i> blue ring bague bleu anillo azul	<i>Kreuzverzahnt standard</i> x-cut, medium Denture croisée, moyenne Dentado cruzado, medio	... GX	190	
	<i>grüner Ring</i> green ring anneau vert anillo verde	<i>Kreuzverzahnt grob</i> x-cut, coarse Denture croisée, grosse Dentado cruzado, grueso	... HX	220	
	<i>schwarzer Ring</i> black ring anneau noir anillo negro	<i>Kreuzverzahnt super grob</i> x-cut, super coarse Denture croisée, très grosse Dentado cruzado, super grueso	... SX	224	
	<i>roter Ring</i> red ring anneau rouge anillo rojo	<i>Querhiebverzahnt fein</i> Cross cut, fine Denture surtaillée, fine Dentado transversal, fino	... FQ	134	
	<i>roter Ring</i> red ring anneau rouge anillo rojo	<i>Minis wie FX</i> Minis like FX Minis comme FX Minis como FX	... MF	140	
	<i>blauer Ring</i> blue ring anneau bleu anillo azul	<i>Minis wie GX</i> Minis like GX Minis comme GX Minis como GX	... MG	220	

C71

ID-No.	025	031	040	050
500 104 001 175 ...	025	031	040	050

C72

ID-No.	060
500 104 137 175 ...	060
L mm	13,7

C75

ID-No.	060	070
500 104 260 175 ...	060	070
L mm	12,0	13,2

C77

ID-No.	050	060
500 104 237 175 ...	050	060
L mm	10,7	11,7

C78

ID-No.	060
500 104 257 175 ...	060
L mm	12,7

C79

ID-No.	040	045	060	070
500 104 194 175 ...	040	045	060	070
L mm	14,2	12,7	12,7	14,7

C416

ID-No.	060
500 104 201 175 ...	060
L mm	14,7

C75 G

ID-No.	060	070
500 104 260 215 ...	060	070
L mm	12,0	13,2

H · HP · PM · PM

... 104 ...

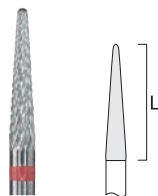

C23 FX

ID-No.	023
500 104 199 140 ...	023
L mm	11,5



C72 FX

ID-No.	060
500 104 137 140 ...	060
L mm	13,7



C75 FX

ID-No.	060
500 104 260 140 ...	060
L mm	12,0



C77 FX

ID-No.	060
500 104 237 140 ...	060
L mm	11,7

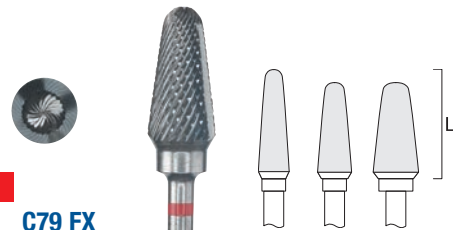

C79 FX

ID-No.	040	045	060
500 104 194 140 ...	040	045	060
L mm	14,2	12,7	12,7

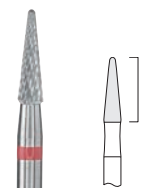

C138 FX

ID-No.	023
500 104 198 140 ...	023
L mm	8,0

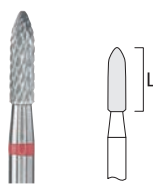

C139 FX

ID-No.	023
500 104 289 140 ...	023
L mm	8,0





C251 FX

ID-No.	040	060
500 104 274 140 ...	040	060
L mm	9,3	14,7



H · HP · PM · PM

... 104



C486 FX

ID-No.	023
500 104 137 140 ...	023
L mm	14,0



C487 FX

ID-No.	023
500 104 292 140 ...	023
L mm	14,0

C489 FX

ID-No.	023
500 104 187 140 ...	023
L mm	15,0

C23 GX

ID-No.	023
500 104 199 190 ...	023
L mm	11,5

C72 GX

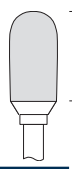
ID-No.	060
500 104 137 190 ...	060
L mm	13,7

C73 GX

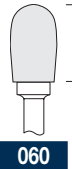
ID-No.	060
500 104 277 190 ...	060
L mm	10,0

C75 GX

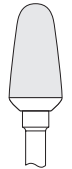
ID-No.	060
500 104 260 190 ...	060
L mm	12,0

H · HP · PM · PM

 ... 104 ...



Hartmetall-Fräser

Carbide cutters · Fraises au carbure · Fresas de carburo



C77 GX

ID-No.	060
500 104 237 190 ...	060
L mm	11,7

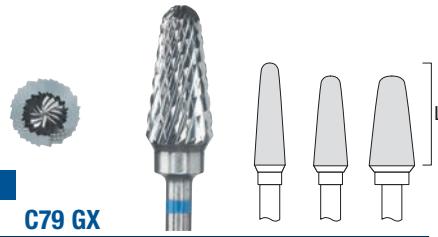

C79 GX

ID-No.	040	045	060
500 104 194 190 ...	040	045	060
L mm	14,2	12,7	12,7

2



C138 GX

ID-No.	023
500 104 198 190 ...	023
L mm	8,0



C139 GX

ID-No.	023
500 104 289 190 ...	023
L mm	8,0



C251 GX

ID-No.	040
500 104 274 190 ...	040
L mm	9,3



C416 GX

ID-No.	060
500 104 201 190 ...	060
L mm	14,7



C460 GX

ID-No.	023
500 104 116 190 ...	023
L mm	14,0



C486 GX

ID-No.	023
500 104 137 190 ...	023
L mm	14,0

H · HP · PM · PM



C487 GX

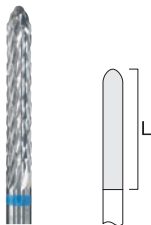

ID-No.	023
500 104 292 190 ...	023
L mm	14,0

C79 HX

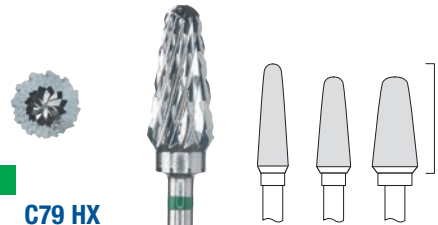

ID-No.	040	045	060
500 104 194 220 ...	040	045	060
L mm	14,2	12,7	12,7

C251 HX



ID-No.	060
500 104 274 220 ...	060
L mm	14,7

C72 SX



ID-No.	060
500 104 137 224 ...	060
L mm	13,7

C251 SX



ID-No.	060
500 104 274 224 ...	060
L mm	14,7

C23 MF

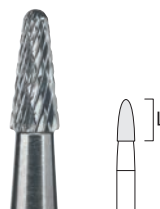

ID-No.	023
500 104 196 140 ...	023
L mm	5,5

C30 MF

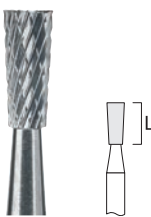

ID-No.	023
500 104 225 140 ...	023
L mm	5,5

H · HP · PM · PM

 ... **104** ...



Hartmetall-Fräser

Carbide cutters · Fraises au carbure · Fresas de carburo

C77 MF

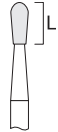
ID-No.	023
500 104 237 140 ...	023
L mm	5,5

C78 MF

ID-No.	023
500 104 257 140 ...	023
L mm	5,5

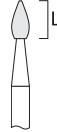
C23 MG

ID-No.	023
500 104 196 220 ...	023
L mm	5,5

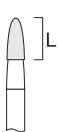
C30 MG

ID-No.	023
500 104 225 220 ...	023
L mm	5,5

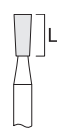
C77 MG

ID-No.	023
500 104 237 220 ...	023
L mm	5,5

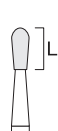
C78 MG

ID-No.	023
500 104 257 220 ...	023
L mm	5,5

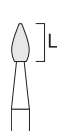
H · HP · PM · PM





C79 FQ

ID-No.	040
500 104 194 134 ...	040
L mm	14,2

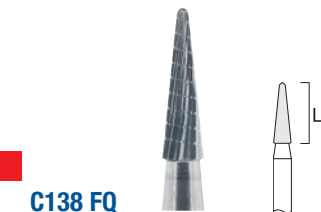

C138 FQ

ID-No.	023
500 104 198 134 ...	023
L mm	8,0



C251 FQ

ID-No.	060
500 104 274 134 ...	060
L mm	14,7

2

H · HP · PM · PM

 ... 104



Chirurgische-Bohrer

Surgical burs · Fraises chirurgicales · Fresas quirúrgicas





Chirurgische-Bohrer

Surgical burs · Fraises chirurgicales · Fresas quirúrgicas



C141

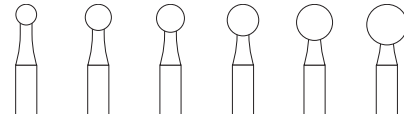

	ID-No.	023	027	031	035	040	045	050
500 105 001 291 ...		023	027	031	035	040	045	050
500 205 001 291 ...		023						

6 Schneiden
 6 blades
 6 lames
 6 laminas

3



141 RF

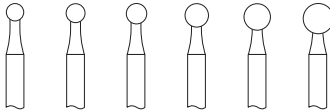

	ID-No.	023	025	027	031	035	040	
330 104 001 291 ...		023	025	027	031	035	040	6 Schneiden - Rostfrei
330 204 001 291 ...		023						6 blades - Stainless
330 206 001 291 ...		023						6 lames - Inoxydable
								6 laminas - Inoxidable

H · HP · PM · PM

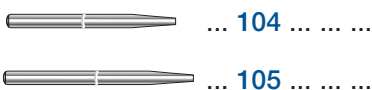

W · RA · CA · CA



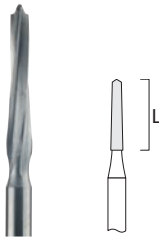

161 RF

ID-No.	016	Rostfrei
330 316 408 295 ...	016*	Stainless
		Inoxydable
		Inoxidable
L mm	9,0	
316	*max. 120.000 min ⁻¹	

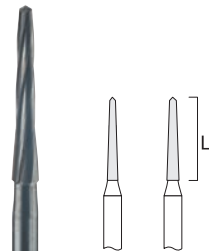

C 161

ID-No.	014	016	Hartmetall
500 206 408 295 ...	014	016	tungsten carbide
500 316 408 295 ...	014*	016*	carbure
			carburo
L mm	11	11	
316	*max. 120.000 min ⁻¹		

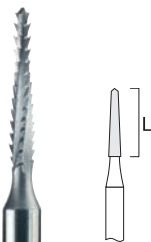

162 RF

ID-No.	016	Rostfrei
330 205 408 297 ...	016	Stainless
330 316 408 297 ...	016*	Inoxydable
		Inoxidable
L mm	9,0	
316	*max. 120.000 min ⁻¹	

W · RA · CA · CA

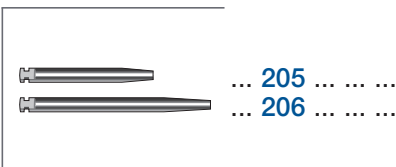

FG · FG · FG · FG





Knochen-Fräser

Bone cutters · Fraises à os · Fresas para huesos

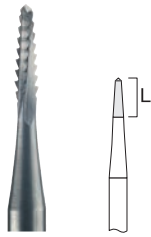

163 RF

ID-No.	014	Rostfrei
330 104 406 297 ...	014	Stainless
		Inoxydable
		Inoxidable
L mm	5,0	

3

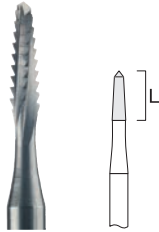

164 RF

ID-No.	018	Rostfrei
330 104 407 297 ...	018	Stainless
330 205 407 297 ...	018	Inoxydable
		Inoxidable
L mm	6,0	

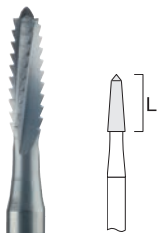

165 RF

ID-No.	023	Rostfrei
330 104 408 297 ...	023	Stainless
330 205 408 297 ...	023	Inoxydable
		Inoxidable
L mm	7,0	

H · HP · PM · PM



W · RA · CA · CA



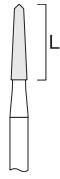

166 RF

ID-No.	021	Rostfrei
330 104 409 297 ...	021	Stainless
330 205 409 297 ...	021	Inoxydable Inoxidable
L mm	10,0	

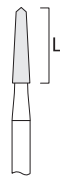

167 RF

ID-No.	023	Rostfrei
330 104 410 297 ...	023	Stainless
330 205 410 297 ...	023	Inoxydable Inoxidable
L mm	10,0	



168 RF

ID-No.	023	Rostfrei
330 105 411 297 ...	023	Stainless
		Inoxydable Inoxidable
L mm	22,0	

3

H · HP · PM · PM



... **104** ...
... **105** ...

W · RA · CA · CA

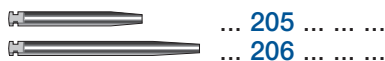

... **205** ...
... **206** ...



Wurzelkanal-Instrumente

Root canal instruments · Intruments à canaux · Instrumentos para canales

4



Wurzelkanal-Instrumente

Root canal instruments · Instruments à canaux · Instrumentos para canales

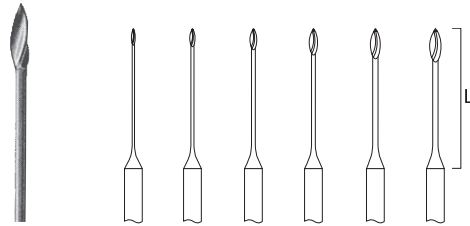

180 GR

	ID-No.	050	070	090	110	130	150
	L mm						
330 206 679 336 ...	19	050	070	090	110	130	150
330 206 679 336 ...	19	(Set 050-150)					

Wurzelkanalerweiterer «Gates» - Rostfrei
 Root canal reamers «Gates» - Stainless
 Elargisseurs radiculaires «Gates» - Inoxydable
 Ensanchadores radiculares «Gates» - Inoxidable

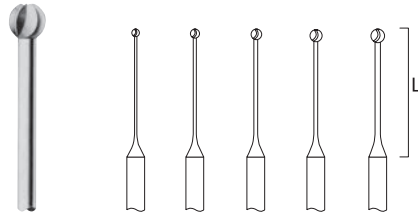

191 R

	ID-No.	100	120	140	160	180
	L mm					
330 206 698 001 ...	18	100	120	140	160	180
330 206 698 001 ...	18	(Set 100-180)				

Pulpakammerbohrer «Müller» - Rostfrei
 Pulp chamber bur «Müller» - Stainless
 Fraises à chambre pulpaire «Müller» - Inoxydable
 Fresas radiculares «Müller» - Inoxidable

4

W · RA · CA · CA



Spezial-Werkzeuge

Special tools · Outils spéciaux · Herramientas especiales





Carbide Twist-Drill

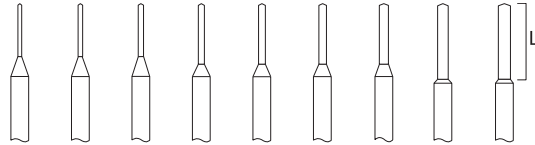

C 203

ID-No.	005	006	007	008	009	010	012	014	016
500 104 417 364 ...	005	006	007	008	009	010	012	014	016
L mm	8	8	8	8	8	8	8	10	10



C 219

ID-No.	012
500 104 467 211 ...	012
L mm	4,2

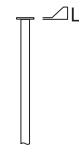

C 231

ID-No.	023
500 104 045 171...	023
L mm	0,2

5



303 RF

ID-No.	050
330 104 603 391 ...	050

*Rostfrei
Stainless
Inoxydable
Inoxidable*





H · HP · PM · PM



Diamant-Instrumente

Diamond instruments · Instruments diamantés · Instrumentos de diamantados



	<i>Farbcodierung</i> Colour code Code couleurs Código colores	<i>Körnung</i> Grain Grain Grano	<i>Fig.</i> Fig. Fig. Fig.	<i>ID-No.</i> ID-No. ID-No. ID-No.	<i>Korngröße</i> Size of grain Taille de Grain Grado de granos
	<i>grüner Ring</i> green ring anneau vert anillo verde	<i>grob</i> coarse gros grueso	<i>... G</i>	<i>534</i>	<i>151 µm</i>
	<i>ohne Ring</i> without ring sans bague sin anillo	<i>Standard</i> Standard Standard Standard		<i>524</i>	<i>120 µm</i>
	<i>roter Ring</i> red ring anneau rouge anillo rojo	<i>fein</i> fine fin fino	<i>... F</i>	<i>514</i>	<i>40 µm</i>
	<i>gelber Ring</i> yellow ring anneau jaune anillo amarillo	<i>extra fein</i> extra fine extra fin extra fino	<i>... C</i>	<i>504</i>	<i>20 µm</i>
	<i>weißer Ring</i> white ring anneau blanc anillo blanco	<i>ultra fein</i> ultra fine ultra fin ultra fino	<i>... U</i>	<i>494</i>	<i>10 µm</i>



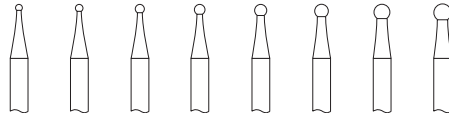

801

	ID-No.	009	010	012	014	016	018	021	023
801	806 104 001 524 ...		010	012	014	016	018	021	023
801	806 204 001 524 ...		010	012	014	016	018		
801 G	806 314 001 534 ...		010	012	014	016	018	021°	023°
801	806 314 001 524 ...	009	010	012	014	016	018	021°	023°
801 F	806 314 001 514 ...		010	012	014	016	018	021°	023°
801 C	806 314 001 504 ...				014	016	018		
° max. 300.000 min ⁻¹									

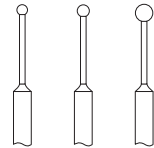

801 L

	ID-No.	014	016	023
801 L G	806 314 697 534 ...	014°	016°	023*
801 L	806 314 697 524 ...	014°	016°	023*
° max. 300.000 min ⁻¹ * max. 160.000 min ⁻¹				

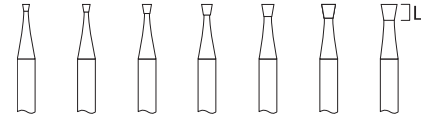

805

	ID-No.	009	010	012	014	016	018	021
805	806 204 010 524 ...	009	010	012				
805 G	806 314 010 534 ...			012	014	016	018	021
805	806 314 010 524 ...		010	012	014	016	018	021
	L mm	1,0	1,0	1,2	1,6	1,6	1,6	1,9

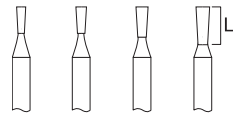

807

	ID-No.	012	014	016	018
807 G	806 314 225 534 ...	012	014	016	018
807	806 314 225 524 ...	012	014	016	018
	L mm	3,5	3,5	4	5,0

H · HP · PM · PM



... 104 ...

W · RA · CA · CA



... 204 ...

FG · FG · FG · FG



... 314 ...



Diamant-Instrumente

Diamond instruments · Instruments diamantés · Instrumentos de diamantados

		830				
		ID-No.	010	012	014	016
830 G		806 314 238 534 ...	010	012	014	016
830		806 314 238 524 ...	010	012	014	016
		L mm	2,7	2,7	2,7	2,7

		830 L				
		ID-No.	012	014	016	018
830 L G		806 314 239 534 ...	012	014	016	018
830 L		806 314 239 524 ...	012	014	016	018
		L mm	4	5	5	5

		835				
		ID-No.	010	012	014	016
835 G		806 314 107 534 ...	010	012	014	
835		806 314 107 524 ...	010	012	014	016
		L mm	4	4	4	4

		835 KR			
		ID-No.	010	012	014
835 KR G		806 314 156 534 ...	010	012	014
835 KR		806 314 156 524 ...	010	012	014
		L mm	4	4	4

		836				
		ID-No.	010	012	014	016
836		806 204 110 524 ...	010	012		
836 G		806 314 110 534 ...	010	012	014	016
836		806 314 110 524 ...	010	012	014	016
		L mm	6	6	6	6

		836 KR				
		ID-No.	010	012	014	016
836 KR G		806 314 157 534 ...	010	012	014	016
836 KR		806 314 157 524 ...	010	012	014	016
		L mm	6	6	6	6

		837				
		ID-No.	010	012	014	016
837 G		806 314 111 534 ...	010°	012°	014	016
837		806 314 111 524 ...		012°	014	016
			° max. 300.000 min ⁻¹			
		L mm	8	8	8	8

		837 KR				
		ID-No.	010	012	014	016
837 KR G		806 314 158 534 ...	010°	012°	014	016
837 KR		806 314 158 524 ...	010°	012°	014	
			° max. 300.000 min ⁻¹			
		L mm	8	8	8	8

W · RA · CA · CA

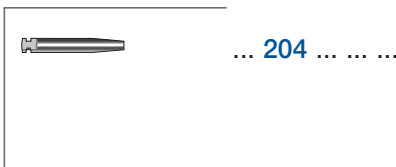

FG · FG · FG · FG

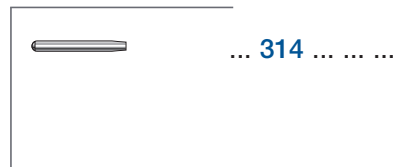

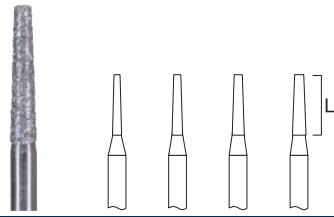

		847				
		ID-No.	012	014	016	018
847 G	■	806 314 172 534 ...	012°	014°	016	018
847		806 314 172 524 ...	012°	014°	016	
		° max. 300.000 min ⁻¹				
		L mm	8	8	8	8



		847 KR	
		ID-No.	016
847 KR G	■	806 314 546 534 ...	016
847 KR		806 314 546 524 ...	016
		L mm	8

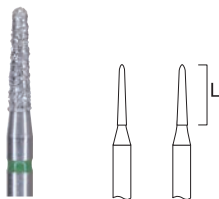

		855		
		ID-No.	012	014
855 G	■	806 314 197 534 ...	012	014
855		806 314 197 524 ...	012	014
855 F	■	806 314 197 514 ...	012	014
		L mm	6	6



		856			
		ID-No.	014	016	018
856 G	■	806 314 198 534 ...	014	016	018
856		806 314 198 524 ...	014	016	018
856 F	■	806 314 198 514 ...	014	016	018
		L mm	8	8	8

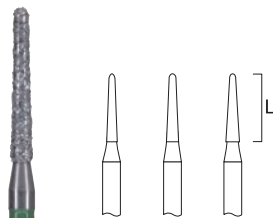

		856 L			
		ID-No.	014	016	018
856 L G	■	806 314 199 534 ...	014*	016*	018*
856 L		806 314 199 524 ...	014*	016*	018*
856 L F	■	806 314 199 514 ...	014*	016*	018*
		*max. 120.000 min ⁻¹			
		L mm	9	9	9

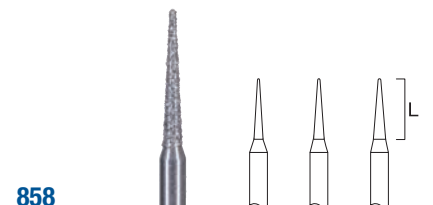

		858			
		ID-No.	012	014	016
858 G	■	806 314 165 534 ...	012°	014°	016
858		806 314 165 524 ...	012°	014°	016
858 F	■	806 314 165 514 ...	012°	014°	
858 C	■	806 314 165 504 ...		014°	016
		° max. 300.000 min ⁻¹			
		L mm	8	8	8

FG · FG · FG · FG

... 314



Diamant-Instrumente

Diamond instruments · Instruments diamantés · Instrumentos de diamantados

859

		ID-No.	010	012	014	016	018
859		806 104 166 524 ...			014	016	018
859 G	■	806 314 166 534 ...	010°	012°	014°	016°	018°
859		806 314 166 524 ...	010°	012°	014°	016°	018°
859 F	■	806 314 166 514 ...	010°	012°	014°	016°	018°
859 C	■	806 314 166 504 ...	010°	012°	014°	016°	018°
		*max. 300.000 min ⁻¹					
		L mm	10	10	10	10	10

859 L

		ID-No.	010	012
859 L G	■	806 314 167 534 ...	010°	012°
859 L		806 314 167 524 ...	010°	012°
859 L F	■	806 314 167 514 ...	010°	012°
		*max. 300.000 min ⁻¹		
		L mm	11,5	11,5

862

		ID-No.	009	010	012	014
862 G	■	806 314 249 534 ...		010*	012*	014
862		806 314 249 524 ...		010*	012*	014
862 F	■	806 314 249 514 ...	009*	010*	012*	014
862 C	■	806 314 249 504 ...	009*	010*	012*	014
		*max. 160.000 min ⁻¹				
		L mm	8	8	8	8

863

		ID-No.	010	012	014	016
863 G	■	806 314 250 534 ...		012*	014*	016*
863		806 314 250 524 ...	010*	012*	014*	016*
863 F	■	806 314 250 514 ...	010*	012*	014*	016*
863 C	■	806 314 250 504 ...	010*	012*	014*	016*
		*max. 160.000 min ⁻¹				
		L mm	10	10	10	10

878

		ID-No.	010	012	014	016
878 G	■	806 314 289 534 ...	010*	012*	014	016
878		806 314 289 524 ...	010*	012*	014	016
878 F	■	806 314 289 514 ...	010*	012*	014	016
		*max. 160.000 min ⁻¹				
		L mm	8	8	8	8

878 K

		ID-No.	012	014
878 K G	■	806 314 298 534 ...	012°	014
878 K		806 314 298 524 ...	012°	014
		*max. 300.000 min ⁻¹		
		L mm	8	8

H · HP · PM · PM

... 104 ...

FG · FG · FG · FG

... 314 ...

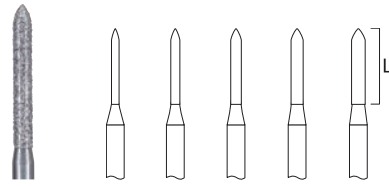

879

		ID-No.	010	012	014	016	018
879 G	■	806 314 290 534 ...	010*	012*	014°	016°	018°
879		806 314 290 524 ...	010*	012*	014°	016°	018°
879 F	■	806 314 290 514 ...	010*	012*	014°	016°	018°
			* max. 160.000 min ⁻¹		° max. 300.000 min ⁻¹		
		L mm	10	10	10	10	10

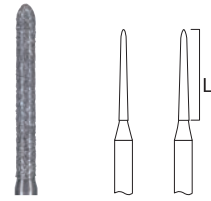

879 L

		ID-No.	012	014
879 L G	■	806 314 291 534 ...	012*	014*
879 L		806 314 291 524 ...	012*	014*
879 L F	■	806 314 291 514 ...	012*	014*
			* max. 160.000 min ⁻¹	
		L mm	12	12

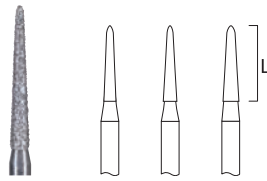

879 K

		ID-No.	016	018	021
879 K G	■	806 314 299 534 ...	016°	018°	021°
879 K		806 314 299 524 ...	016°	018°	021°
879 K F	■	806 314 299 514 ...	016°	018°	021°
			° max. 300.000 min ⁻¹		
		L mm	10	10	10

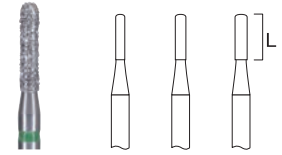

880

		ID-No.	012	014	016
880 G	■	806 314 140 534 ...	012	014	016
880		806 314 140 524 ...	012	014	016
880 F	■	806 314 140 514 ...	012	014	016
		L mm	6	6	6

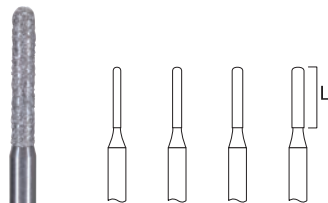

881

		ID-No.	010	012	014	016
881 G	■	806 314 141 534 ...	010°	012°	014	016
881		806 314 141 524 ...	010°	012°	014	016
881 F	■	806 314 141 514 ...	010°	012°	014	016
			° max. 300.000 min ⁻¹			
		L mm	8	8	8	8

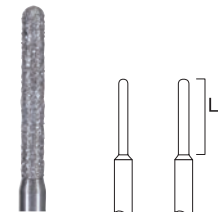

882

		ID-No.	012	014
882 G	■	806 314 142 534 ...	012°	014°
882		806 314 142 524 ...	012°	014°
882 F	■	806 314 142 514 ...	012°	014°
			° max. 300.000 min ⁻¹	
		L mm	10	10

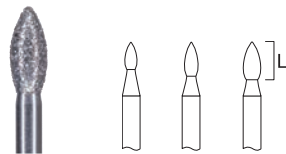

368

		ID-No.	016	018	023
368		806 314 257 524 ...	016	018	023°
368 F	■	806 314 257 514 ...	016	018	023°
368 C	■	806 314 257 504 ...	016	018	023°
			° max. 300.000 min ⁻¹		
		L mm	3,5	4,5	5

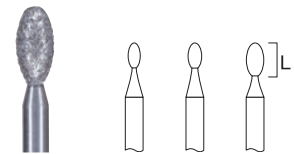

379

		ID-No.	016	018	023
379 G	■	806 314 277 534 ...	016	018	023°
379		806 314 277 524 ...	016	018	023°
379 F	■	806 314 277 514 ...	016	018	023°
379 C	■	806 314 277 504 ...	016	018	023°
			° max. 300.000 min ⁻¹		
		L mm	3,4	3,5	4,5

FG · FG · FG · FG



... 314

**BS 314 030**

30 FG-Instrumente
30 FG instruments
30 FG instruments
30 instrumentos FG

**BS 204 030**

30 Winkelstück-Instrumente
30 RA instruments
30 CA instruments
30 instrumentos CA

BS 204/314 084

42 FG- und 42 Winkelstück-Instrumente
42 FG and 42 RA instruments
42 FG et 42 CA instruments
42 instrumentos FG & 42 instrumentos CA

**BS 314 084**

84 FG-Instrumente
84 FG instruments
84 FG instruments
84 instrumentos FG

**BS 204 084**

84 Winkelstück-Instrumente
84 RA instruments
84 CA instruments
84 instrumentos CA

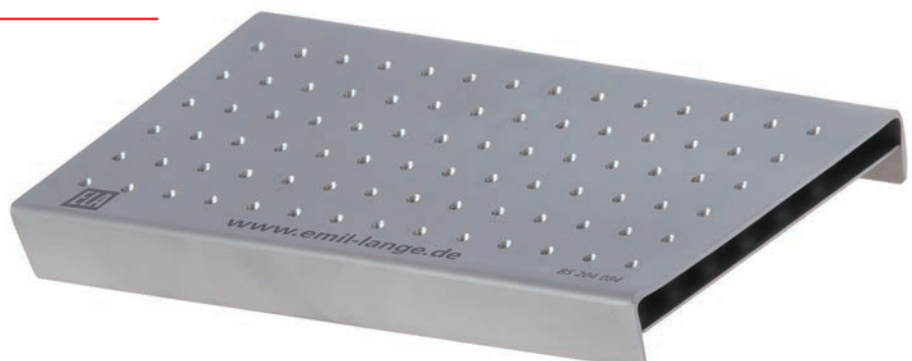

*sterilisierbar bis max. 138°C,
sterilizable up to 138°C max,
stérilisé à max. 138 °C,
esterilizable hasta 138 °C*

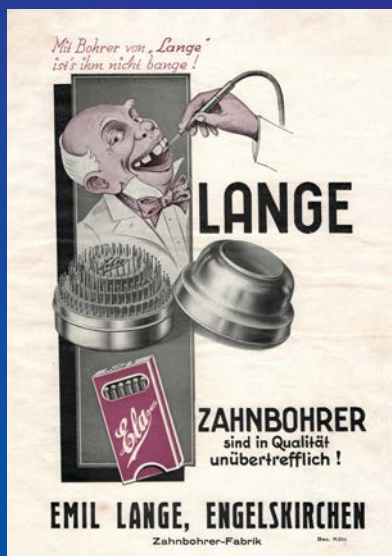

EMIL LANGE • Zahnbohrerfabrik e.K.

Leppestraße 62 • D-51766 Engelskirchen

Tel. +49 (0) 2263 9 29 44-0 • Fax +49 (0) 2263 9 29 44 44

www.emil-lange.de • eMail: info@emil-lange.de